

Attached table 7 Shape and dimensions of curl spool for tubing

Shape and dimensions of spool for tubing shall be pursuant to **Attached table 7**.

Unit : mm

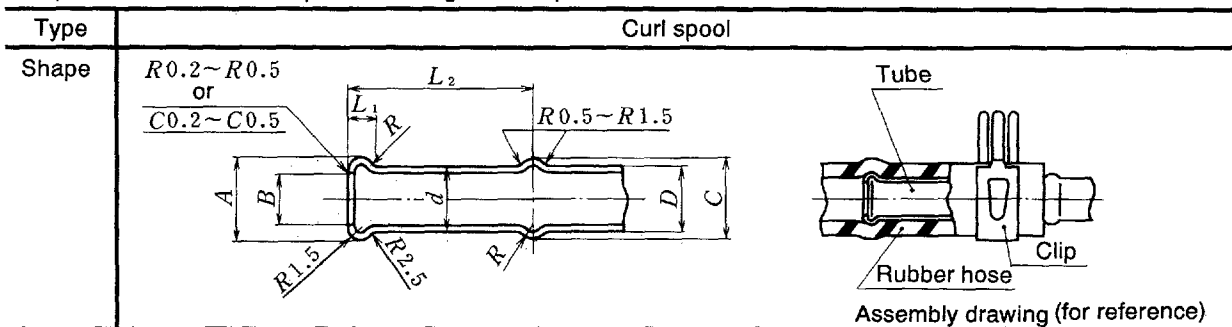

Assembly drawing (for reference)

Nominal diameter	D		A		B		C		L ₁		L ₂		d	
	*1	Tolerance	*1	Tolerance	*1	Tolerance	*1	Tolerance	*1	Tolerance	*1	Tolerance	*1	Tolerance
4.76	4.76	±0.08	5.6	±0.3	3.0	±0.3	5.6	±0.5	3.0	±0.1	28	±2.0	4.76	+0.2 -0.1
6.35	6.35		7.4		4.3		7.4				28		6.35	
8	8		9.3		6.1		9.3				33		8.0	
10	10	±0.1	11.5	±0.3	7.0	±0.3	11.9	±0.5	3.0	±0.1	33	±2.0	10.0	+0.2 -0.1
12	12		13.5		8.0		13.5				33		12.0	
15	15		16.7		11.0		16.7				33		15.0	
18	18		19.7		14.0		19.7				33		18.0	

Remark : Nominal diameters which are not specified in **Attached table 7** shall be mutually agreed upon by the purchaser and the manufacturer.

Attached table 8 Shape and dimensions of O-ring flare for tubing

Shape and dimensions of O-ring flare for tubing shall be pursuant to **Attached table 8**.

Unit : mm

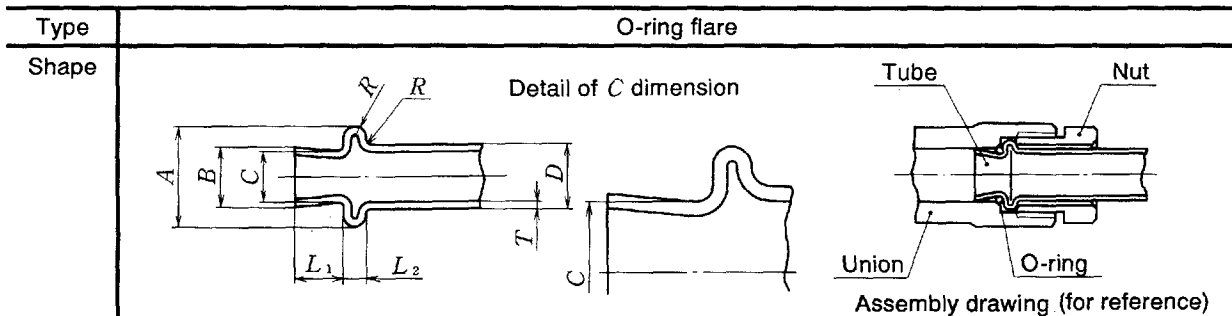

Assembly drawing (for reference)

Nominal diameter	D		A		B		C		L ₁		L ₂		T		R ₁
	*1	Tolerance	*1	Tolerance	*1	Tolerance	*1	Tolerance	*1	Tolerance	*1	Tolerance	*1	Tolerance	-
6.35	6.35	±0.08	9.5	0 -0.3	5.2	+0.1 -0.2	4.6	±0.1	4.5	0 -0.5	1.8	±0.2	0.7	±0.08	0.3-0.6
8.0	8.0		11.8		7.2		6.4				1.8		0.7		0.3 <
10	10		13.5		9.2		8.0				2.6		1.0		0.75-1.0

Remark : Nominal diameters which are not specified in **Attached table 8** shall be mutually agreed upon by the purchaser and the manufacturer.

*1 : Standard dimension